

INCREMENTAL ENCODER

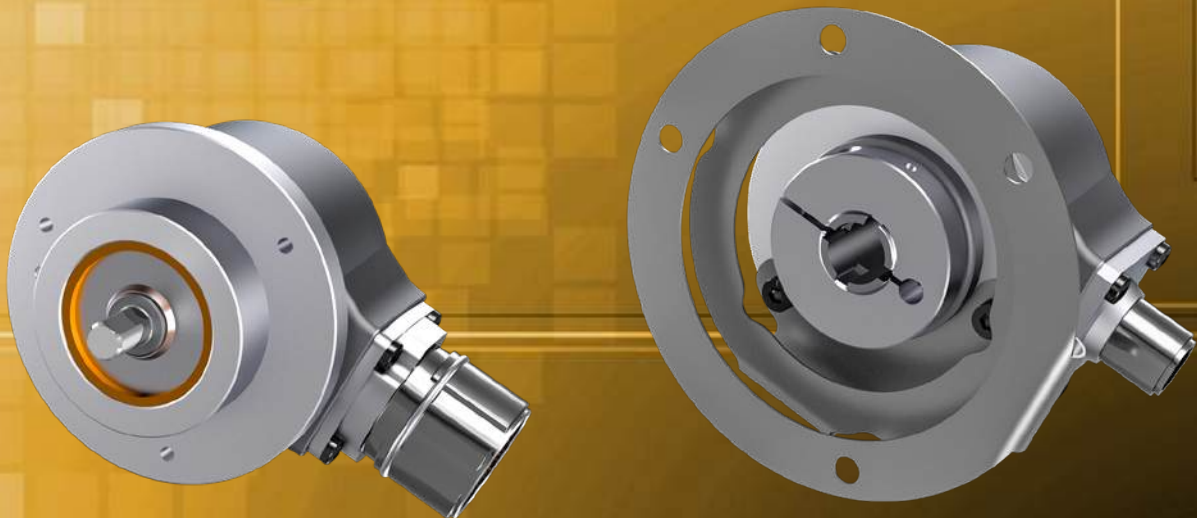

Content:

Technical Data2
Electrical Data2
Technical Drawing Solid Shaft3
Technical Drawing Hollow Shaft5
Mounting Accessories7
Measuring Wheels, Encoder Arm8
Order Code9
Accessories	..10

Series B58

Key-Features:

- Incremental output: Linedriver RS422 (TTL-compatible), Push-Pull, Open Collector
- Shaft types: solid shaft or hollow shaft
- Flange types: synchro flange, clamping flange, square flange, Euro flange, servo flange, flange with spring element, flange with torque stop, flange with stator coupling
- Protection class IP66, optional IP67
- Temperature range -40 up to +85 °C
- Output frequency up to 300 kHz
- Rotation speed up to 12000 r/min
- Shaft material stainless steel

TECHNICAL DATA

Shaft type		solid shaft	hollow shaft
Shaft dimensions	[mm] [in]	($\varnothing \times L$): 6 x 10 / 8 x 15 / 10 x 20 / 11 x 33 ¹⁾ / 12 x 20 ($\varnothing \times L$): 1/4 x 5/8, 3/8 x 5/8, 1/4 x 7/8, 3/8 x 7/8	(\varnothing): 6 / 8 / 10 / 12 / 14 / 15 (\varnothing): 1/4, 3/8, 1/2, 5/8
Flange type	[mm]	synchro flange \varnothing : 50.8 / 58 clamping flange \varnothing : 58 square flange: 52.3 / 63.5 Euro flange ²⁾ \varnothing : 115 servo flange \varnothing : 50.8 / 63.5	with spring element with torque stop stator coupling \varnothing : 57.2 / 63 / 65
Impulses		1 / 2 / 4 / 5 / 10 / 12 / 14 / 20 / 25 / 28 / 30 / 32 / 36 / 50 / 60 / 64 / 80 / 100 / 120 / 125 / 150 / 180 / 200 / 240 / 250 / 256 / 300 / 342 / 360 / 375 / 400 / 500 / 512 / 600 / 625 / 720 / 800 / 900 / 1000 / 1024 / 1200 / 1250 / 1500 / 1800 / 2000 / 2048 / 2500 / 3000 / 3600 / 4000 / 4096 / 5000	
Output signal		see electrical data below	
Connection		cable output, connector M12 or M23	
Mechanical speed	[min ⁻¹]	standard: 12000 (continuous 6000) / Option IP67: 6000 (continuous 3000)	
Mass moment of inertia	[kgm ²]	ca. 1.8×10^{-6}	ca. 6×10^{-6}
Starting torque (at 20 °C)	[Nm]	standard: <0.01 / Option IP67: <0.05	
Shaft load capacity	[N]	radial: 100 / axial: 50	
Protection class		IP65 (optional: shaft IP66, housing IP67)	
Temperature	[°C]	connector output: -40...+85 / cable fixed installation: -30...+85 / cable flexible installation: -20...+85	
Shock resistance		3000 m/s ² , 6 ms (according to EN 60068-2-27)	
Vibration resistance		300 m/s ² , 10...2000 Hz (according to EN 60068-2-6)	
Shaft material		stainless steel	
Weight	[g]	approx. 400	

¹⁾ with feather key shaft slot, only in combination with Euro flange

²⁾ only in combination with solid shaft 11 x 33

ELECTRICAL DATA

		Linedriver RS422 (TTL-compatible)		Push Pull HTL	Push Pull HTL (7272-compatible)	Push Pull HTL (7272-compatible, without capacitor)	Open collector (7273)
Order code		L	L2	G	G2	G3	C
Power supply	[VDC]	5 ±5%	5...30	10...30		5...30	
Power consumption (no load)	[mA]	typical: 40, max.: 90		typical: 50, max.: 100			100
Permissible load / channel	[mA]	max. ±20					20 sink at 30 VDC
Impulse frequency max.	[kHz]	300			300 ¹⁾	300	
Signal level HIGH	[V]	min. 2.5		min. +V -1	min. +V -2		-
Signal level LOW	[V]	max. 0.5					-
Rising edge time t _r	[ns]	max. 200		max. 1000			-
Falling edge time t _f	[ns]	max. 200		max. 1000			-
Short circuit proof outputs ²⁾		yes ³⁾		yes		yes ³⁾	yes
Reverse polarity protection of power supply		yes	no	yes	no		
UL approval		File-Nr. E224618					
CE compliant		according to EMC guideline 2014/30/EU and RoHS guideline 2011/65/EU					

¹⁾ maximal recommended cable length 30 m

²⁾ if power supply is applied correctly

³⁾ only one channel allowed to be shorted-out:

At +V = 5 VDC short circuit is permitted to channel, 0 V or +V.

At +V = 5...30 VDC short circuit is permitted to channel or 0 V.

TECHNICAL DRAWING SOLID SHAFT

Synchro flange Ø 50.8 mm

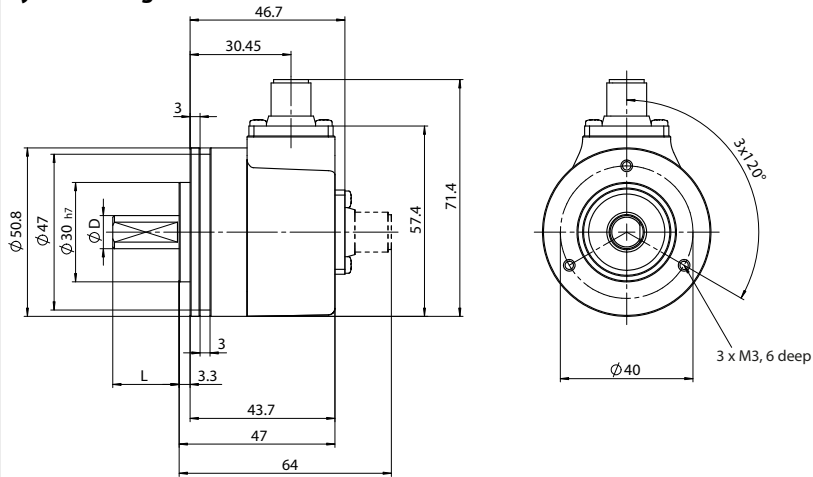

Synchro flange Ø 58 mm

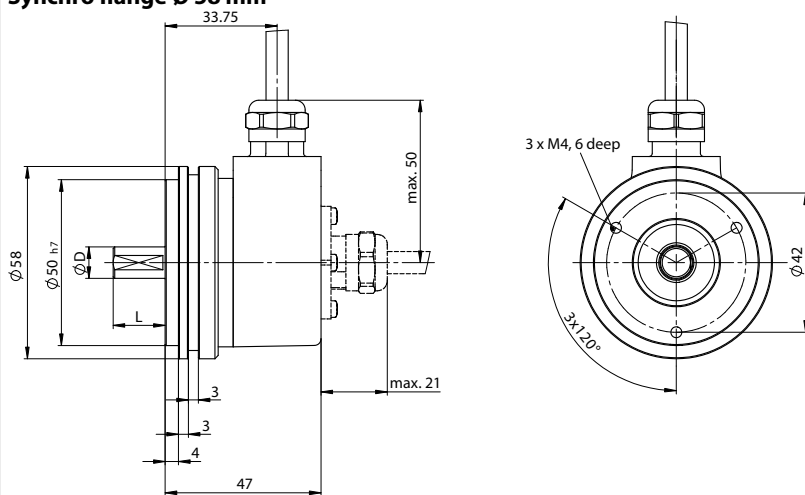

Clamping flange Ø 58 mm

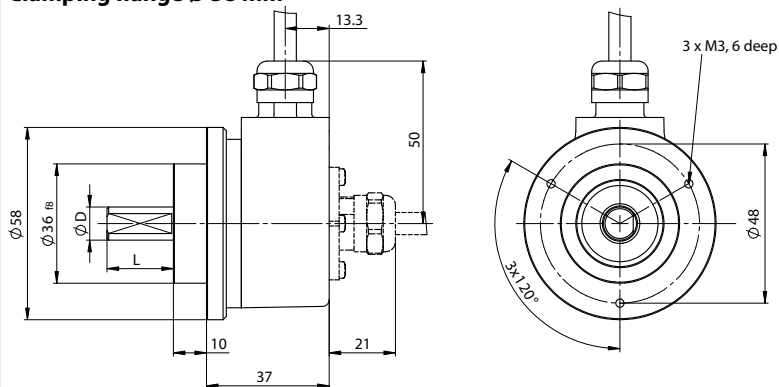

D	Fit	L
6 mm	h7	10 mm
8 mm	h7	15 mm
10 mm	f7	20 mm
12 mm	h7	20 mm
1/4"	h7	5/8"
3/8"	h7	5/8"
1/4"	h8	7/8"
3/8"	h8	7/8"

TECHNICAL DRAWING SOLID SHAFT

Square flange Ø 52.3 mm

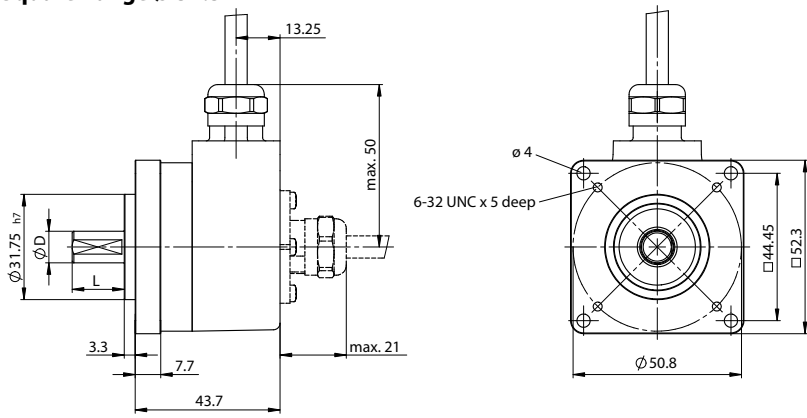

Square flange Ø 63.5 mm

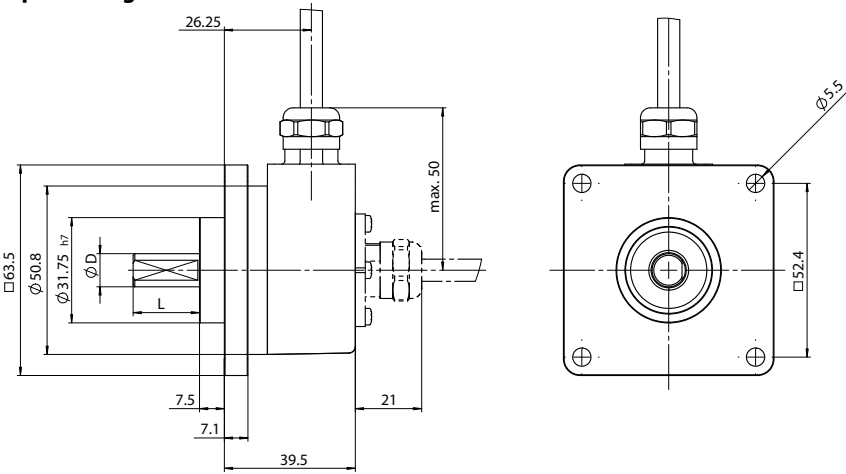

D	Fit	L
6 mm	h7	10 mm
8 mm	h7	15 mm
10 mm	f7	20 mm
12 mm	h7	20 mm
1/4"	h7	5/8"
3/8"	h7	5/8"
1/4"	h8	7/8"
3/8"	h8	7/8"

Euro flange Ø 115 mm

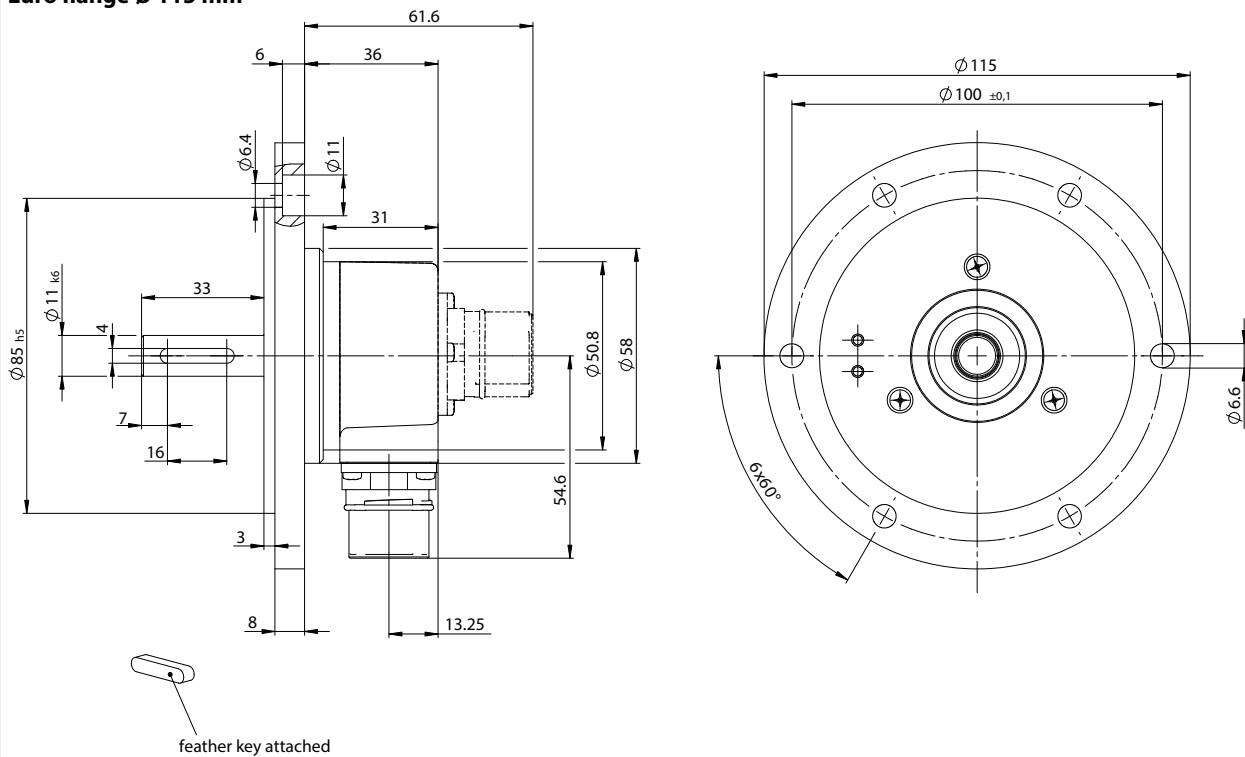

TECHNICAL DRAWING SOLID SHAFT

Servo flange Ø 50.8 mm

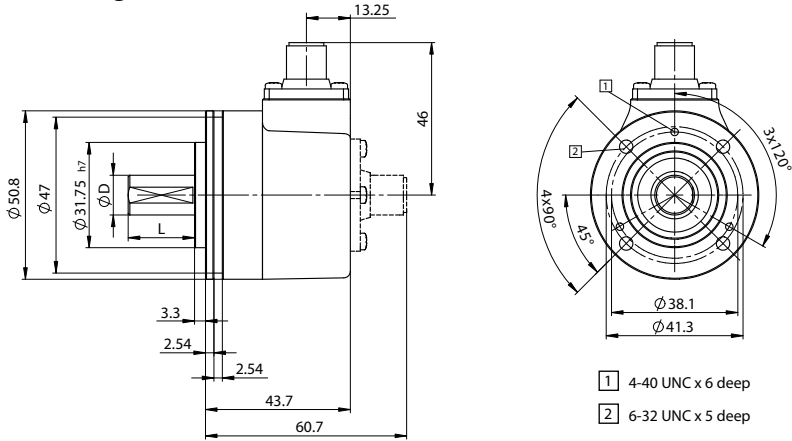

Servo flange Ø 63.5 mm

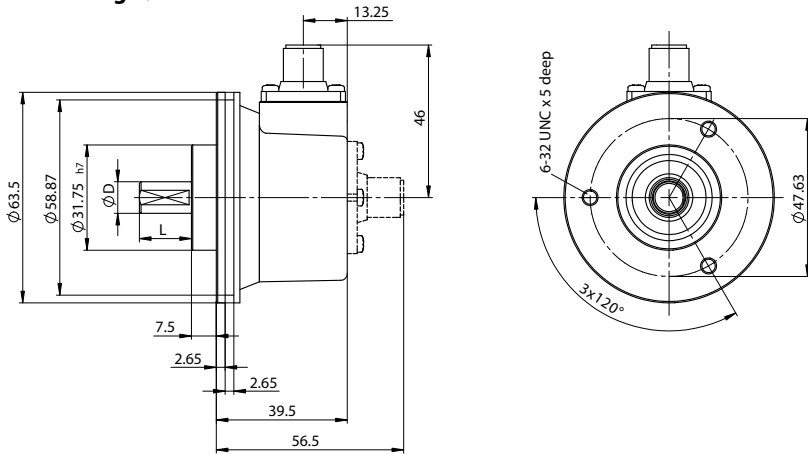

D	Fit	L
6 mm	h7	10 mm
8 mm	h7	15 mm
10 mm	f7	20 mm
12 mm	h7	20 mm
1/4"	h7	5/8"
3/8"	h7	5/8"
1/4"	h8	7/8"
3/8"	h8	7/8"

TECHNICAL DRAWING HOLLOW SHAFT

Flange with spring element Flange with spring element, radial cable output or connector output

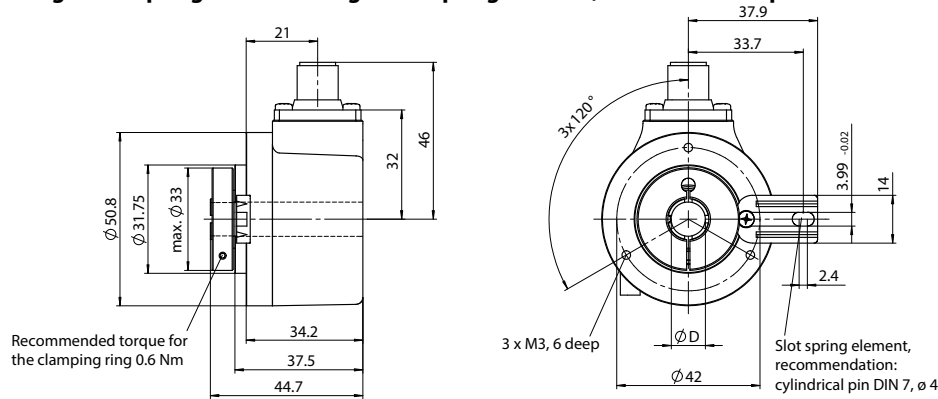

Recommended torque for the clamping ring 0.6 Nm

D	Fit
6 mm	H7
8 mm	H7
10 mm	H7
12 mm	H7
14 mm	H7
15 mm	H7
1/4"	H7
3/8"	H7
1/2"	H7
5/8"	H7

TECHNICAL DRAWING HOLLOW SHAFT

Flange with spring element, tangential cable output

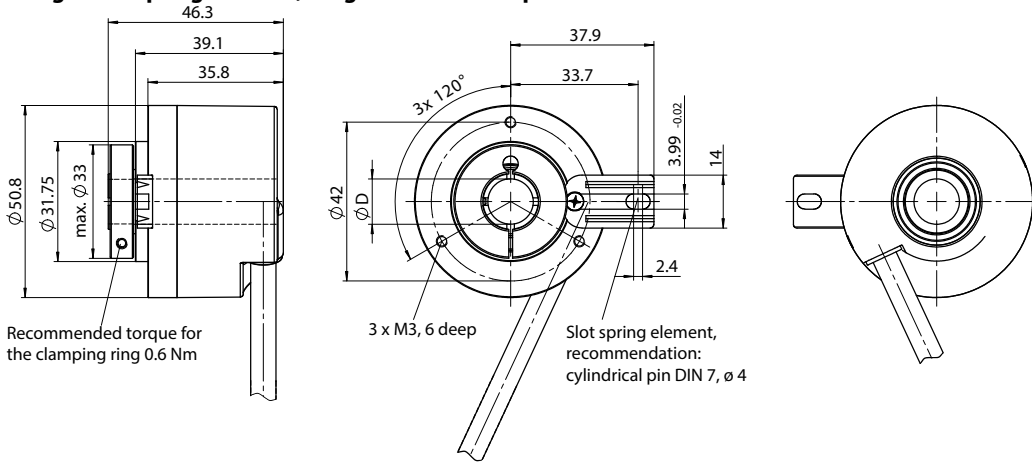

Flange with torque stop

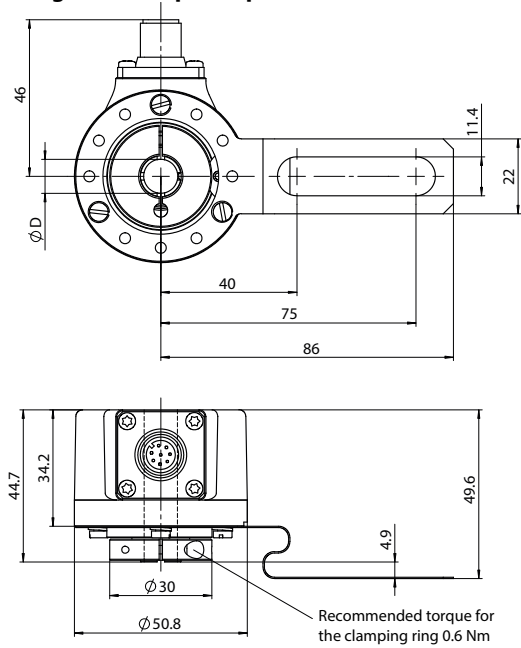

Flange with stator coupling Ø 57.2 mm

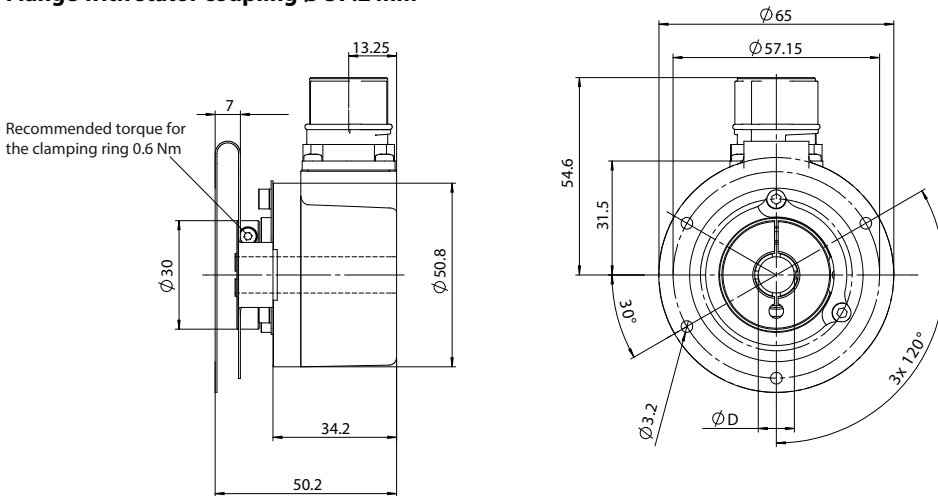

D	Fit
6 mm	H7
8 mm	H7
10 mm	H7
12 mm	H7
14 mm	H7
15 mm	H7
1/4"	H7
3/8"	H7
1/2"	H7
5/8"	H7

TECHNICAL DRAWING HOLLOW SHAFT

Flange with stator coupling Ø 63 mm

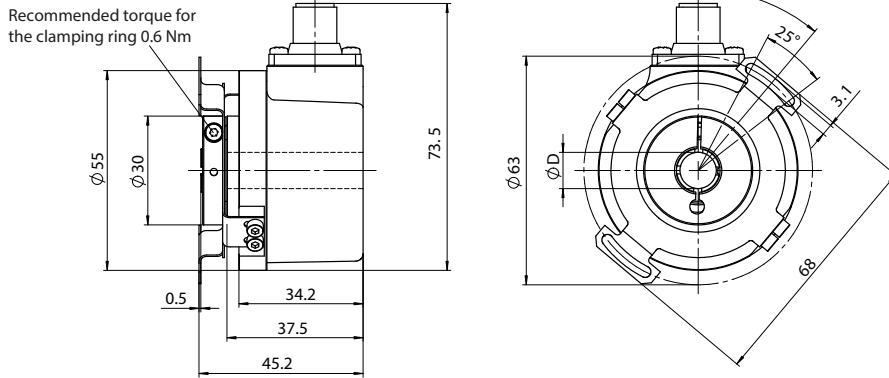

Flange with stator coupling Ø 65 mm

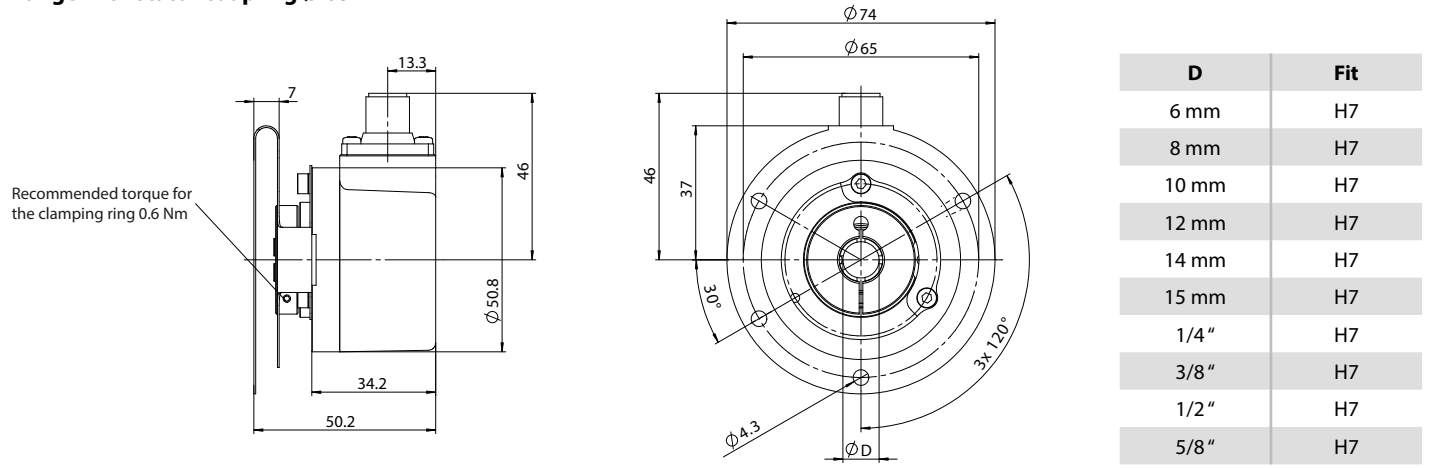

MOUNTING ACCESSORIES

Bellow couplings for Encoder with solid shaft 6 or 10

Rotary transducers should never be connected to shafts or drives in an inflexible, stiff way. For this reason, we recommend using a coupling between the rotary transducer and the shaft. Bellow couplings are used for the free of backlash connection between an encoder and a shaft. The couplings are free of wear and compensate lateral, axial and angular shaft misalignment. The mounting on the shaft is done by clamping hubs. Never use force to align the rotary angle transducer!

MBK-15.5-23-06-06

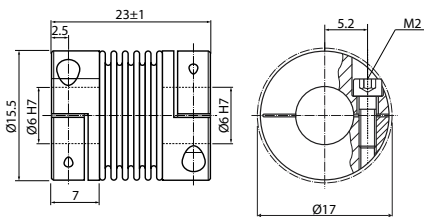

MBK-20-26-06-10

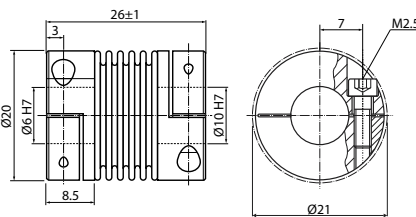

MBK-20-26-10-10

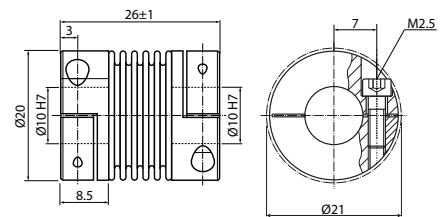

Cylindrical pin with fixing thread for flange with spring element

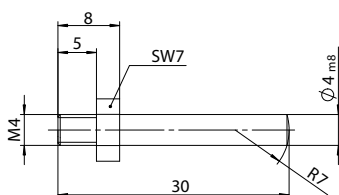

Isolation / adapter inserts for hollow shaft encoders with shaft diameter Ø 15 mm

Thermal and electrical isolation of the encoders (temperature range -40...+115 °C): Isolation inserts prevent currents from passing through the encoder bearings. These currents can occur when using inverter controlled three-phase or AC vector motors and considerably shorten the service life of the encoder bearings. In addition the encoder is thermally isolated as the plastic does not transfer the heat to the encoder.

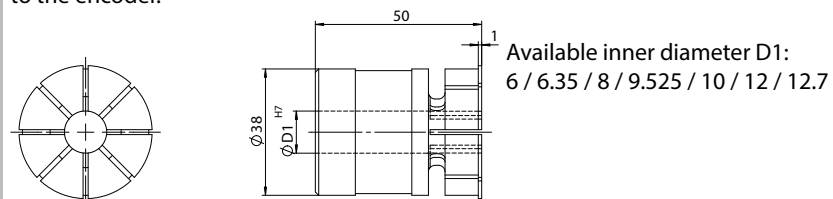

ACCESSORIES MEASURING WHEELS AND SPRING ENCODER ARM

Measuring wheels for measuring the length of products in movement, e.g. in the paper, metal, textile, wood or plastic industry.

Circumference	[m]	0.2	0.5	0.3048
Diameter	[mm]	63.7	159.2	97.028
Width	[mm]	12	25	9.652
Bore diameter	[mm]		10	
Weight	[g]	60	775 (Profile 1), 700 (Profiles 2, 3, 4)	100
Temperature	[°C]		-30...+80	
Material of wheel body		Aluminium		
Profile		1. diamond knurl (aluminium) / 2. plastic (polyurethane), smooth / 3. tufted rubber (polyurethane) / 4. plastic (polyurethane), corrugated		5. natural rubber (NR), smooth

Surface of the measured material	Recommended profile
Cardboard	1, 2, 3, 4, 5
Wood	1, 2, 3, 4, 5
Textile	1, 2, 3, 4
Plastic (PVC, PE, ...)	2, 3, 4, 5
Paper	2, 3, 4, 5
Wire, greased metals, steel profiles, leather	2
Carpet, cables, nonwoven	3
Greased metals, glass, floor coverings	4
Painted surfaces	2, 4
Rubber, soft plastic	1

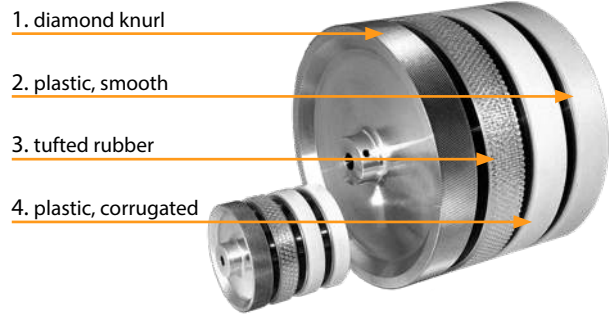

Please note:

If a measuring wheel is mounted directly on the shaft of a rotary encoder, the pressure force between the measuring wheel and measured material should not exceed the radial shaft load listed in this data sheet.

In addition, the measuring wheels can only be used for in-house purposes which are not subject to the stipulations of the German calibration code.

Spring encoder arm for encoder with solid shaft Ø 10 mm

- Spring encoder arm for easy mounting of a measuring wheel with Encoder
- Base plate variable in 4 directions
- Material: Aluminium and spring steel
- Contact force max.: 40 N
- Temperature range: -40...70 °C
- Shock resistance: 1000 m/s², 6 ms (acc. EN 60068-2-27)
- Vibration resistance: 100 m/s², 55...2000 Hz (acc. EN 60068-2-6)

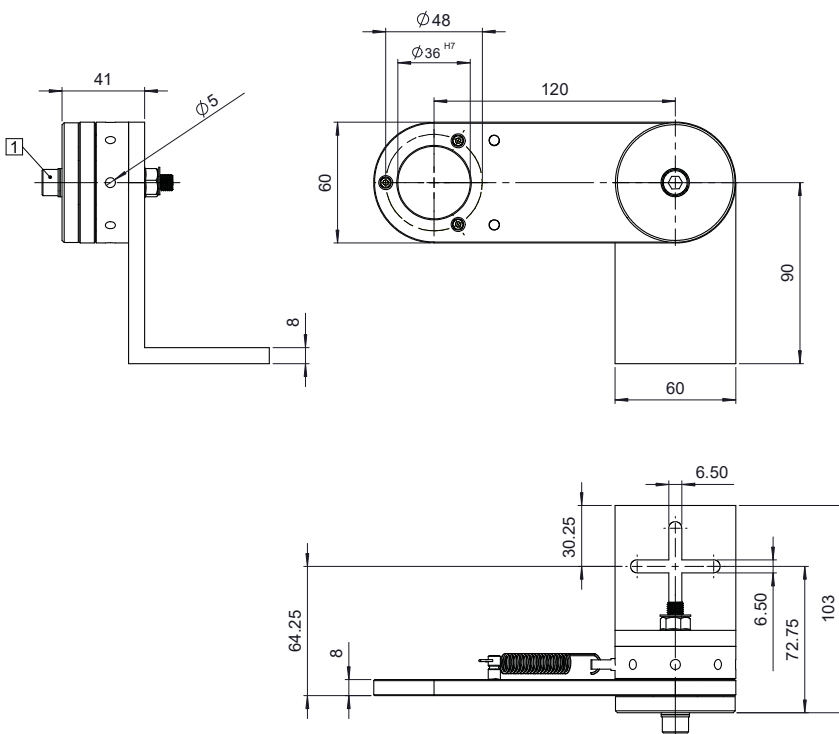

1 Screw M8x60 DIN912 (SW6)

ORDER CODE

B58 - □ - □ - □ - □ - □ - □

Flange type [mm]	
Solid shaft	
<i>Clamping flange Ø 58</i>	<i>W</i>
Synchro flange Ø 50.8	S2
<i>Synchro flange Ø 58</i>	<i>S</i>
Square flange 52.3	Q2
Square flange 63.5	Q
Euro flange Ø 115 (shaft 11 only)	E
Servo flange Ø 50.8	V
Servo flange Ø 63.5	V2
Hollow shaft	
<i>Flange with spring element</i>	<i>F</i>
<i>Flange with torque stop</i>	<i>D</i>
Flange with stator coupling Ø 57.2	K3
<i>Flange with stator coupling Ø 63</i>	<i>K2</i>
<i>Flange with stator coupling Ø 65</i>	<i>K</i>

Solid / hollow shaft diameter	
Solid shaft Ø x L	
<i>6 x 10 mm</i>	<i>6</i>
8 x 15 mm	8
<i>10 x 20 mm</i>	<i>10</i>
11 x 33 (Euro flange E only)	11
12 x 20 mm	12
1/4 x 5/8 "	6.35L
1/4 x 7/8 "	6.35
3/8 x 5/8 "	9.5L
3/8 x 7/8 "	9.5
Hollow shaft Ø	
6 mm	6
<i>8 mm</i>	<i>8</i>
<i>10 mm</i>	<i>10</i>
<i>12 mm</i>	<i>12</i>
14 mm	14
<i>15 mm</i>	<i>15</i>
1/4 "	6.35
3/8 "	9.25
1/2 "	12.75
5/8 "	15.875

Protection class	
-	Standard IP65 ¹⁾
<i>IP6Z</i>	<i>Shaft IP66, housing IP6Z</i>

Connection	
<i>KA01</i>	<i>Cable output, axial, 1 m</i> ³⁾
<i>KR01</i>	<i>Cable output, radial, 1 m</i>
KT01	Cable output, tangential, 1 m ²⁾
<i>SA12</i>	<i>Connector M12, axial, 8 pins</i> ³⁾
<i>SR12</i>	<i>Connector M12, radial, 8 pins</i>
<i>SA23</i>	<i>Connector M23, axial, 12 pins</i> ³⁾
<i>SR23</i>	<i>Connector M23, radial, 12 pins</i>

Impulses	
e. g. 14	<i>1 / 2 / 4 / 5 / 10 / 12 / 14 / 20 / 25 / 28 / 30 / 32 / 36 / 50 / 60 / 64 / 80 / 100 / 120 / 125 / 150 / 180 / 200 / 240 / 250 / 256 / 300 / 342 / 360 / 375 / 400 / 500 / 512 / 600 / 625 / 720 / 800 / 900 / 1000 / 1024 / 1200 / 1250 / 1500 / 1800 / 2000 / 2048 / 2500 / 3000 / 3600 / 4000 / 4096 / 5000</i>

Output signal	
<i>L</i>	<i>RS422 (TTL-compatible, 5 VDC)</i>
<i>L2</i>	<i>RS422 (TTL-compatible, 5...30 VDC)</i>
<i>G</i>	<i>Push Pull (10...30 VDC)</i>
<i>G2</i>	<i>Push Pull (7272-comp., 5...30 VDC)</i>
G3	Push Pull (7272-compatible, without capacitor, 5...30 VDC)
<i>C</i>	<i>Open Collector (5...30 VDC)</i>

- ¹⁾ Euro flange standard shaft IP66, housing IP67
- ²⁾ Encoder with hollow shaft only
- ³⁾ Encoder solid shaft only

Encoders that consist entirely of underlined italic options have a shortened delivery time.

ACCESSORIES

Cable with mating connector M12 (female), 8 poles, shielded

K8P2M-S-M12	2 m, straight connector
K8P5M-S-M12	5 m, straight connector
K8P10M-S-M12	10 m, straight connector
K8P2M-SW-M12	2 m, angular connector
K8P5M-SW-M12	5 m, angular connector
K8P10M-SW-M12	10 m, angular connector

Mating connector M12 (female), 8 poles, shielded

D8-G-M12-S	straight connector for self assembly
D8-W-M12-S	angular connector for self assembly

Spring encoder arm and measuring wheels

DGA2-MSR	Spring encoder arm
MSR-02-1	Wheel, diamond knurl, aluminium, circumference 0.2 m
MSR-02-2	Wheel, smooth plastic, polyurethane, circumference 0.2 m
MSR-02-3	Wheel, tufted rubber, polyurethane, circumference 0.2 m
MSR-02-4	Wheel, corrugated plastic, polyurethane, circumference 0.2 m

Couplings

MBK-15.5-23-06-06	2 x bore diameter \varnothing 6 mm
MBK-20-26-06-10	bore diameters \varnothing 6 mm and \varnothing 10 mm
MBK-20-26-10-10	2 x bore diameter \varnothing 10 mm

Digital displays for encoders with Push Pull (HTL) output

WAY-DX-S	2 channel, power supply 18...30 VDC
WAY-DX-AC	2 channel, power supply 115...230 VAC

For more information and options please refer to the [WAY-DX data sheet](#).

Cable with mating connector M23 (female), 12 poles, shielded

K12P2M-S-M23	2 m, straight connector
K12P5M-S-M23	5 m, straight connector
K12P10M-S-M23	10 m, straight connector

Mating connector M23 (female), 12 poles, shielded

CON012-S	straight connector for self assembly, metal housing
----------	---

Spring encoder arm and measuring wheels

MSR-05-1	Wheel, diamond knurl, aluminium, circumference 0.5 m
MSR-05-2	Wheel, smooth plastic, polyurethane, circumference 0.5 m
MSR-05-3	Wheel, tufted rubber, polyurethane, circumference 0.5 m
MSR-05-4	Wheel, corrugated plastic, polyurethane, circumference 0.5 m
MSR-12-5	Wheel, smooth natural rubber (NR), circumference 0.3048 m

Mounting accessories

ZS-M4	Cylindrical pin M4 for flange with spring element
IE15-6	Isolation insert, inner diameter \varnothing 6 mm
IE15-6.35	Isolation insert, inner diameter \varnothing 6.35 mm
IE15-8	Isolation insert, inner diameter \varnothing 8 mm
IE15-9.525	Isolation insert, inner diameter \varnothing 9.525 mm
IE15-10	Isolation insert, inner diameter \varnothing 10 mm
IE15-12	Isolation insert, inner diameter \varnothing 12 mm
IE15-12.7	Isolation insert, inner diameter \varnothing 12.7 mm

Digital displays for encoders with Linedriver (RS422, TTL) output

WAY-DXM-S	2 channel, power supply 18...30 VDC
WAY-DXM-AC	2 channel, power supply 115...230 VAC

For more information and options please refer to the [WAY-DXM data sheet](#).

Subject to change without prior notice.

WayCon Positionsmesstechnik GmbH
 email: info@waycon.de
 internet: www.waycon.biz

WayCon
 Positionsmesstechnik

Head Office
 Mehlsbeerstr. 4
 82024 Taufkirchen
 Tel. +49 (0)89 67 97 13-0
 Fax +49 (0)89 67 97 13-250

Office Köln
 Auf der Pehle 1
 50321 Brühl
 Tel. +49 (0)2232 56 79 44
 Fax +49 (0)2232 56 79 45