

INSTALLATION GUIDE

Magnetic Scale Series MXI11, MXI21 and MXI51

For more information please see the data sheet at
www.waycon.biz/products/magnetic-scales/

FIRST STEPS

WayCon Positionsmesstechnik GmbH would like to thank you for the trust you have placed in us and our products. This manual will make you familiar with the installation and operation of our magnetic scale sensors. Please read this manual carefully before initial operation!

Unpacking and checking:

Carefully lift the device out of the box by grabbing the housing. After unpacking the device, check it for any visible damage as a result of rough handling during the shipment. Check the delivery for completeness.

If necessary consult the transportation company, or contact WayCon directly for further assistance.

SAFETY

- Installation and maintenance have to be carried out by qualified personnel only.
- During installation and maintenance make sure that the machine is not running and the power supply is OFF.
- The encoder must be used only for the purpose appropriate to its design. The use for purposes other than those for which it has been designed could result in serious personal and/or environment damages.
- High current, voltage and moving mechanical parts can cause serious or fatal injury.
- Warning! Do not use in explosive or flammable areas.
- Failure to comply with these precautions or with specific warnings elsewhere in this manual violates safety standards of design, manufacture and intended use of the equipment.
- WayCon assumes no liability for the customer's failure to comply with these requirements.

MECHANICAL SAFETY

- For the installation of the device strictly follow the information in the section "Mounting the sensor".
- Mechanical installation has to be carried out with stationary mechanical parts.
- Do not disassemble the device; do not tool the device.
- Sensitive electronic equipment: handle with care. Do not shock or drop the device.
- During installation we suggest protecting the device against pollution, like chips, filings or liquids. Should this be impossible, please make sure that adequate cleaning measures (as for instance brushes, wipers - see KIT WIPERS order code -, jets of compressed air, etc.) are in place in order to prevent the sensor and the magnetic scale from jamming.

MOUNTING THE SENSOR

- Make sure the mounting tolerances between the sensor and the tape are always met. Avoid contact between the sensor and the magnetic surface.
- Fix the sensor by means of two M3x15 mm cylinder head screws inserted in the provided holes; recommended tightening torque: 1.1 Nm.
- Recommended minimum bend radius of the cable: $R \geq 42$ mm.
- The sensor can be mounted in both directions. The arrow indicates the positive counting direction (A leads B).

Overall dimensions

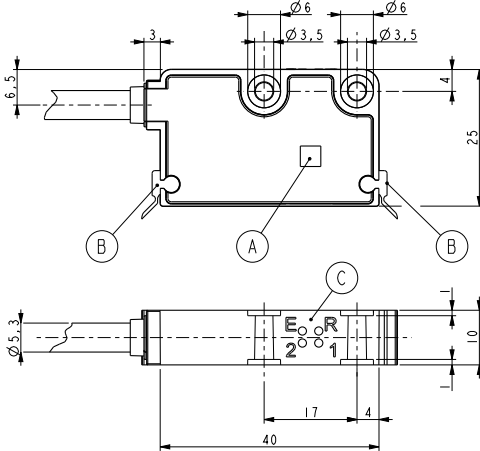

A	Reference Sensor „R“
B	Dust wipers
C	Diagnostic LEDs: E: Gap/Speed error (red) R: Reference detection (green) 1: LED 1 2: LED 2

Recommended mounting tolerances

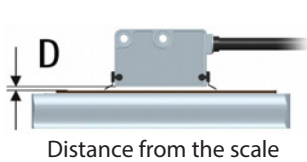

	Gap (D) between sensor and magnetic tape	Gap (D) between sensor and cover strip
MXI11	0.1...0.5 mm	0.1...0.3 mm
MXI21	0.1...1 mm	0.1...0.7 mm
MXI51	0.1...2 mm	0.1...1.7 mm

Lateral deviation
 ± 1.5 mm



Roll $< 3^\circ$



Tilt $< 1^\circ$

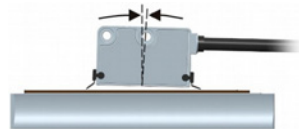

Yaw $< 3^\circ$

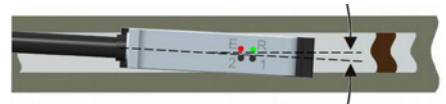

MOUNTING THE SENSOR

The external reference signal is available with „R“ order code and in combination with WKM-1309. It is provided as an alternative to the index signal. It yields a datum position along the scale for use at power-up or following a loss of power. The external reference magnet is placed next to the scale on the side shown in the figure at the preferred location to mark a relevant position in the travel (the home position, for instance). The R LED lights up when the sensor detects the WKM-1309 external reference. If the zero signal is not present on the output or has not the indicated length when the LED is ON, move laterally the reference mark (WKM-1309) of about half a pole length to align it with the scale while keeping the same distance from the sensor.

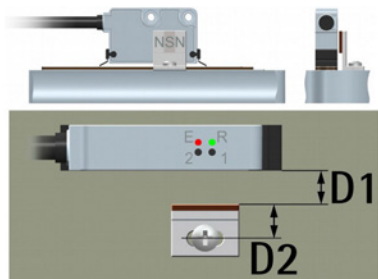

Pay attention to the mounting side!

Sensor and reference	Gap (D1)	Gap (D2)
MXI11 and WKM-1309-1	0.1...0.3 mm	7.3 mm
MXI21 and WKM-1309-2	0.5...0.7 mm	7.5 mm
MXI51 and WKM-1309-5	0.5...1 mm	7.5 mm

ELECTRICAL SAFETY

- Turn OFF the power supply before connecting the device.
- Unconnected wires must be cut at different lengths and insulated singularly.
- Do not stretch the cable. Do not pull or carry by cable. Do not use the cable as a handle.
- In compliance with 2004/108/EC norm on electromagnetic compatibility, following precautions must be taken:
 - Before handling and installing the equipment, discharge electrostatic charges from your body and tools which may come in touch with the device.
 - Power supply must be stabilized without electronic noise. Install EMC filters on device power supply if needed.
 - Always use shielded cables (twisted pair cables whenever possible) and avoid cables longer than necessary.
 - Avoid placing the signal cable near high voltage power cables.
 - Mount the device as far as possible from any capacitive or inductive noise source. Shield the device from electronic noise source if needed.
 - To guarantee a correct working of the device, avoid using strong magnets on or near by the unit.
 - Minimize electronic noise by connecting the cable shield and/or the connector housing and/or the sensor to ground. Make sure that ground is not affected by electronic noise.

ELECTRICAL CONNECTION

Signals	cable output	connector output	K8PXM-S-M12 ³⁾ cable colours
0 Vdc	BK	1	WH
+Vdc ¹⁾	RD	2	BN
A	YE	3	GN
/A	BU	4	YE
B	GN	5	GY
/B	OG	6	PK
0 ²⁾	WH	7	BU
/0 ²⁾	GY	8	RD
Shielding	Shield	Case	Shield

connector output,
M12, male



¹⁾ see order code

²⁾ see order code: I = Index, R = Reference, N = signal not available

³⁾ accessory cable. X = cable length in m

Cable specifications

Type	HI-FLEX M8
Wires	2 x 0.22 mm ² + 6 x 0.14 mm ²
Shield	Tinned copper braid
External Ø	5.3 up to 5.6 mm
Impedance	<90 Ω/Km (0.22 mm ²), <148 Ω/Km (0.14 mm ²)
Min. bend radius	≥ 42 mm

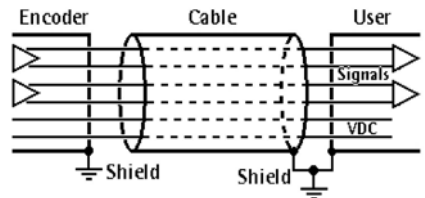

GND connections

Minimize electronic noise by connecting the shield and/or the connector housing and/or the sensor to ground. Make sure that ground is not affected by electronic noise. The connection point to ground can be situated both on the device side and/or on user's side. The best solution to minimize the interference must be carried out by the user.

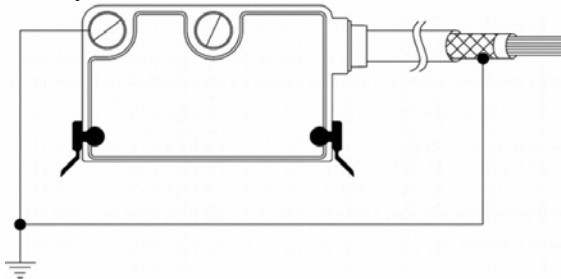

Note: All sensors can provide inverted signals. A = A signal; /A = inverted A signal (or complementary signal). All our magnetic sensors can provide AB0, /AB0 output signals. We advise the inverted signals always be connected if the receiving device will accept them. Otherwise each output should be insulated singularly.

Warning: Connecting /A, /B, or /0 together, to +VDC or to 0 VDC may cause permanent damage to the sensor.

OUTPUT SIGNALS

The conversion electronics inside the sensor translates the magnetic fields of the scale into electrical signals equivalent to those of an incremental encoder or a linear scale. The frequency of the output signal is proportional to the measuring speed and the displacement of the sensor. Resolution after quadrature (4 edges reading) can be determined by the order code of the sensor.

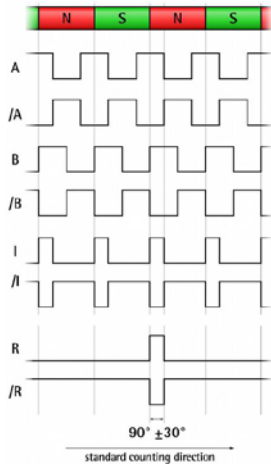

Note: If you need to know the interpolation factor, then you have to divide the pole pitch value by the resolution indicated in the order code.

Warning: The position value issued by the sensor is expressed in pulses; to convert the pulses into a metric measuring unit you must multiply the number of detected pulses by the resolution.

Note: The standard counting direction (the channel A leads the channel B) is to be intended with sensor moving in a linear application.

Index „I“

Index signal is available only with „I“ order code. With either „N“ or „R“ order code the index output signal is not available. The periodic index pulse is synchronized with A and B channels and is provided once per pole. It is always sent at the same position inside the pole, thus the distance between two index pulses is the pole pitch. It has a duration of one measuring step ($90^\circ \pm 30^\circ$).

Reference „R“

The external reference signal is available with „R“ order code and in combination with WKM-1309. It is available as an alternative to the index signal. It provides a datum position along the scale for use at power-up or following a loss of power. The external reference magnet is placed next to the scale on the side shown in the figure at the preferred location to mark a relevant position in the travel (the home position, for instance). The R LED lights up when the sensor detects the WKM-1309 external reference. Please note that this does not mean that the reference pulse is output in the same time: the reference pulse is synchronized with A and B channels within the south pole and has the indicated duration. Thus, it may be either not output yet or already output while the LED is lit. The reference signal has a duration of one measuring step ($90^\circ \pm 30^\circ$). The accuracy and the duration of the reference pulse may vary depending on the alignment of the reference and the magnetic scale.

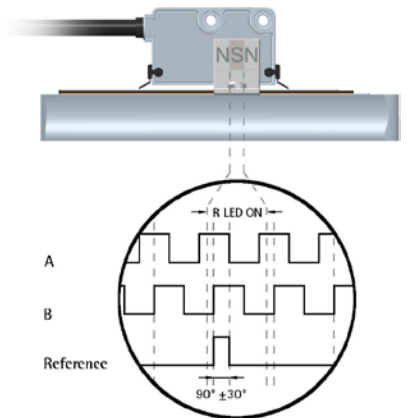

RECOMMENDED CIRCUIT

Push-Pull (Y order code)

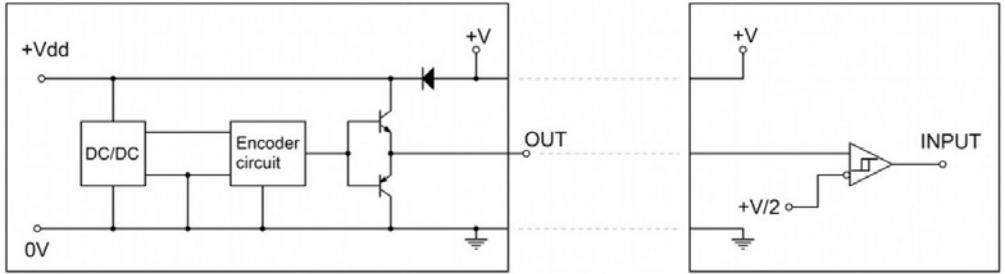

Push-Pull (YC order code)

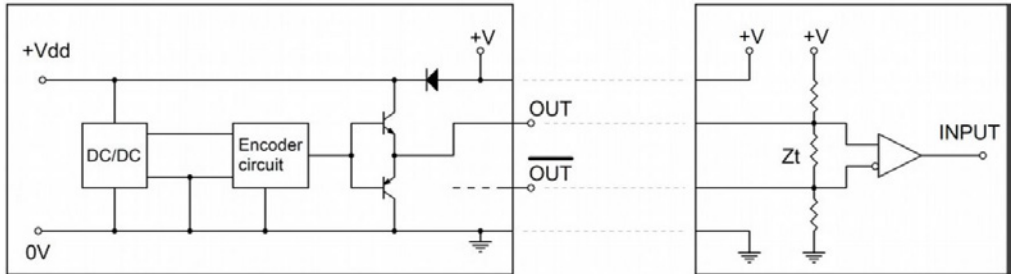

Line Driver (L order code)

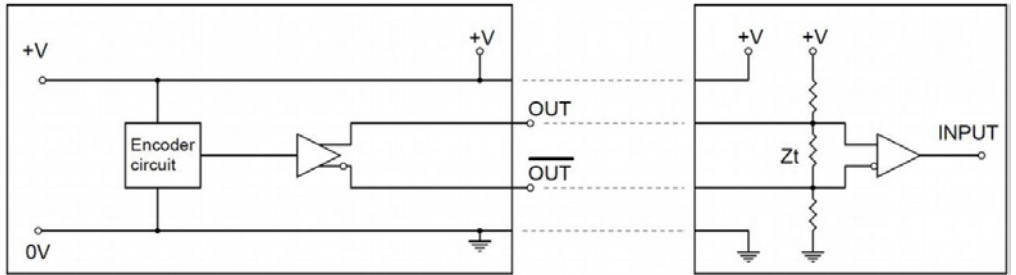

MAINTENANCE

The magnetic measurement system does not need any particular maintenance. Please always consider it is a sensitive electronic equipment and therefore it must be handled with care. From time to time we recommend the following operations:

- Periodically check the proper assembly of the sensor system and make sure that there are no loose screws, tighten them if necessary.
- Check the mounting tolerances between the sensor and the magnetic tape all along the measuring length. Wear of the machine may increase the tolerances.
- The surface of the magnetic tape should be cleaned periodically using a soft cloth to remove dust, chips, moisture etc.

TROUBLESHOOTING

The following list shows some typical faults and errors that may occur during installation and operation of the magnetic measurement system.

Fault: The system does not work (no pulse output).

Possible cause:

- The tape or the sensor has been mounted incorrectly (the active part of the tape does not match the active side of the sensor).
- A magnetic piece or an inappropriate strip is in between the sensor and the tape. Only non-magnetic materials are allowed between the sensor and the tape.
- The sensor touches the tape / ring: the mounting tolerances are not met. Check if the active side of the sensor is damaged.
- The sensor has been damaged by a short circuit or a wrong connection.

Fault: The measured values are inaccurate.

Possible cause:

- The mounting tolerances between the sensor and the tape are not met all along the whole measurement length.
- The connection cable is located next to high voltage cable or the shielding is not connected correctly. See "Electrical connections" section.
- The max. counting frequency of your receiving device is too low.
- A section of the magnetic scale has been damaged mechanically or magnetically along the measuring length.
- The measuring error is caused by torsion of the machine structure. Check parallelism and symmetry of machine movement.



DIAGNOSTIC LEDS

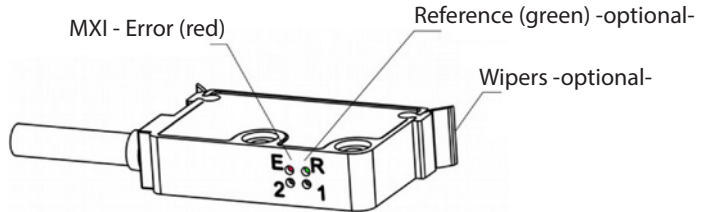

LED	Description
E Error (blinking red)	Error 1: mounting tolerances between the sensor and the scale not met (pulse error), see the "Mounting the sensor" section; Error 2: travelling speed of the sensor too high
R Reference (lit green)	WKM-1309 Reference detection and enabling. It is ON for the whole period length.
1 and 2	Not used by MXI

DECLARATION OF EC-CONFORMITY

WayCon Positionsmesstechnik GmbH
Mehlbeerenstrasse 4
82024 Taufkirchen / Germany

This is to certify that the products

Classification Magnetic scales
Series MXI
fulfill the current request of the following EC-directives:
EMV-directive 2014/30/EU
 2011/65/EU
applied harmonized standards:
CEI EN 61000-6-4, CEI EN 61000-6-2

The declaration of conformity loses its validity if the product is misused or modified without proper authorisation.

Taufkirchen, 02.10.2017

Andreas Täger
CEO